

Schaevitz® A320 Series

Gravity Referenced, Ultra-Low Ranges
Linear Servo Accelerometer



Features

- Fully self-contained - connect to a DC power source and a readout or control device for a complete operating system
- High-level output signal
- $\pm 1/10 g$ to $\pm 2g$ ranges available
- Extremely rugged, withstands 1500g shock

Applications

- Geophysical, seismic and civil engineering studies
- Flight test monitoring
- Structural monitoring
- Low acceleration analysis



DESIGNATION & ORDERING CODE

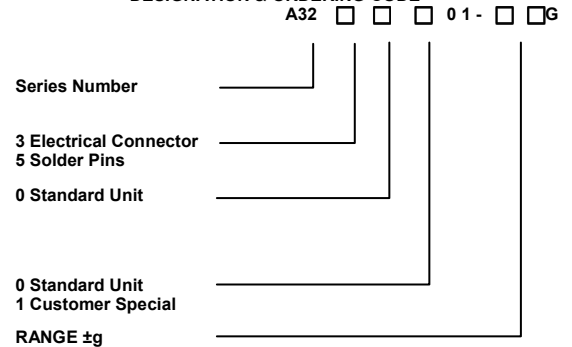

A320

The A320 Series are high precision, closed loop, servo balance, ultra-low range accelerometers that can be used for a wide variety of industrial and aerospace applications. Despite its low measuring range the A320 Series are very robust and shock resistant. Electrical terminations are via 6-pin, bayonet lock connector or solder pins.

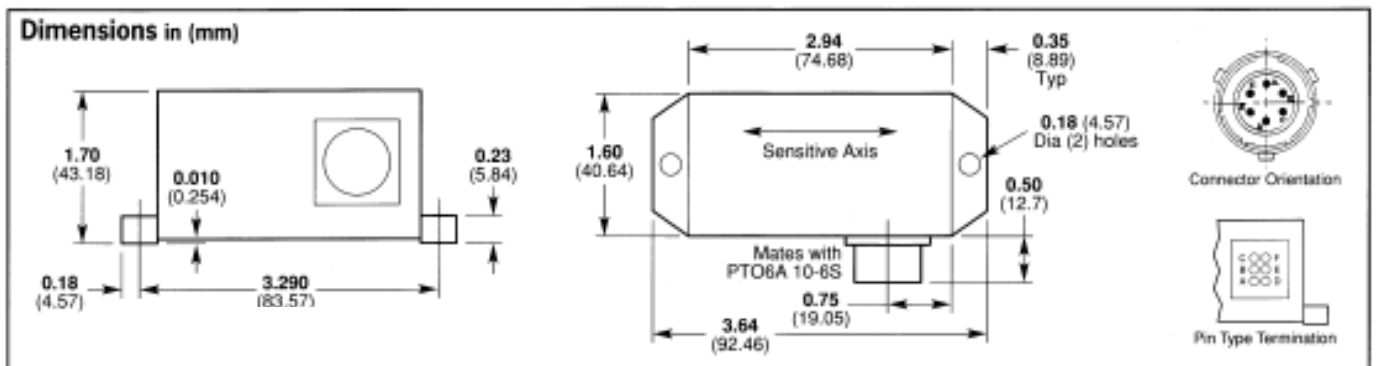

Schaevitz® A320 Series

Gravity Referenced, Ultra-Low Ranges
Linear Servo Accelerometer



Environmental Characteristics

Operating Temperature Range	°C	-18 to 70
Survival Temperature Range	°C	-40 to 70
Constant Acceleration Overload	g	50
Shock Survival		1500g, 0.5msec, ½ sine
Vibration Endurance		35g rms, 20 Hz to 2000 Hz sinusoidal
Environmental Sealing		IP65

Specifications by Range @ 20°C

Ranges		± 0.10g	± 0.25 g	± 0.50g	± 1.00g	± 2.00g
Excitation Voltage	Volts dc			±12 to ±18		
Current Consumption	mA (nom)			±15		
Full Range Output (FRO) (see notes 1 & 5)	Volts dc			±5 (option of ±10Vdc)		
Output Standardisation	% FRO (max)			±2		
Output Impedance	Ω (max)			10		
Output Noise	Vrms (max)			0.002		
Non-Linearity (see note 2)	% FRO (max)			0.05		
Non-Repeatability	% FRO (max)	0.02	0.02	0.015	0.010	0.010
Resolution	% FRO (max)			0.0005		
Frequency Response (-3dB)	Hz (nom)	20	30	40	55	60
Cross-axis sensitivity (see note 4)	g/g (max)			± 0.002		
Zero Offset (see note 3)	Volts dc (max)			± 0.10		
Thermal Zero Shift	%FRO/°C (max)	± 0.03	± 0.01	± 0.005	± 0.005	±0.005
Thermal Sensitivity Shift	%Reading/°C (max)	± 0.03	± 0.01	± 0.006	± 0.006	±0.006

Notes

1. Full Range Output is defined as the peak-to-peak acceleration, i.e. ±1g = 2g peak-to-peak
2. Non-linearity is determined by the method of least squares under constant acceleration conditions.
3. Zero offset is specified under static conditions with no vibration inputs
4. Cross-axis Sensitivity is the output at 90 degrees in cross-axis when tested under static acceleration conditions

How to Order

Specify model type with appropriate range; e.g. an A323 - 0001 - 0.5G is an accelerometer with connector and a range of ±½ g; an A325-0001-0.25G is an accelerometer with pins and a range of ±¼g
Specify Mating Connector 3CON-0009 if required.